

Trio GENERATOR

**YANGDONG
DIESEL ENGINES**

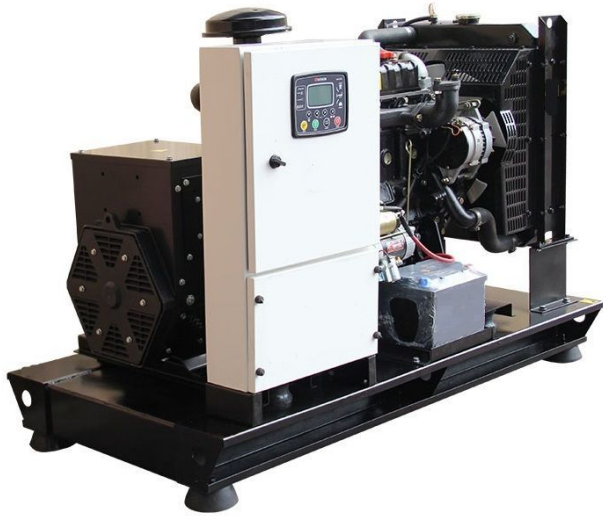

**MADE IN
TURKEY**



DATAKOM

International Organization for Standardization
ISO
14001:2015

INTERNATIONAL STANDARDS ORGANIZATION
ISO 9001



OUTPUT VALUES

Standby Power	Voltage	230/400
Standby Power	kVA	28
Standby Power	kW	22
Standby Power	Amper	40
Prime Power	Voltage	230/400
Prime Power	kVA	25
Prime Power	kW	20
Prime Power	Amper	36

DIESEL ENGINE

Brand	YANG DONG
Model	YS0490D
Max. Total Output Pow. (kW/hp)	33/40
Cylinder Displacement (lt)	2,54
Cylinder Orientation	4 Single Line
Bore x Stroke(mm*mm)	90*100
Compression Ratio	18;1
Governor Type	Mechanic
Rotation	1500 RPM
Aspiration System	Natural
Injection	Direct
Cooling System	Water Cooled
Electrical System(V DC)	12
Oil Capacity (lt)	8
Engine Coolant Capacity (lt)	14
Fuel Cons. %50 (lt/h)	3,12
Fuel Cons. %75 (lt/h)	4,8
Fuel Cons. %100 (lt/h)	6,48

ALTERNATOR

Standby Power (kVa/kw)	31/25
Prime Power (kVa/kw)	28/23
Brand	TRIO
Output Voltage (V)	231/400
Frequency (Hz)	50
Stationary Vol. Regulation(±)	0,01
Short Circuit Current	%300 (10 sec)
Insulation	H
Protection	IP23
Efficiency (%)	94,5
Overloading	110% for 1 hour
Power Factor (cos Q=0.8)	0,8
Tot. Harmonic Dist. Rate	<1 %

Connection Type	Star
Number of Pole	4
Number of Bearing	Single

DIMENSIONS & WEIGHT

Without Canopy	Width	1000 mm
Without Canopy	Length	1800 mm
Without Canopy	High	1500 mm
Without Canopy	Weight	575 kg
Without Canopy	Fuel Tank Capacity	180 lt
With Canopy	Width	1000 mm
With Canopy	Length	2150 mm
With Canopy	High	1650 mm
With Canopy	Weight	650 kg
With Canopy	Fuel Tank Capacity	180 lt

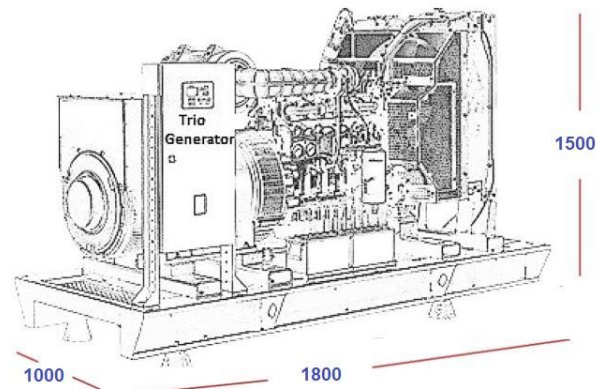
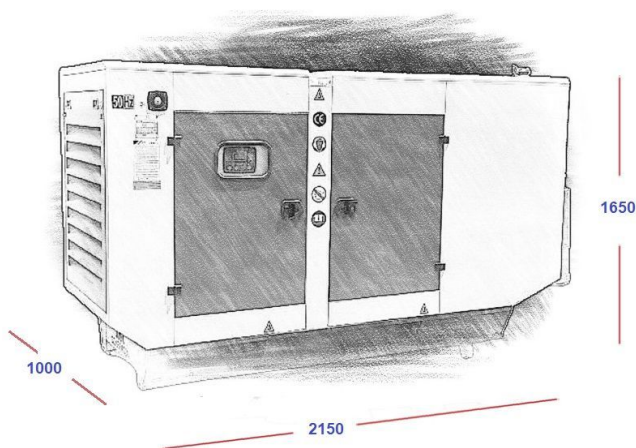

**MADE IN
TURKEY**